

M - 622

Precision Resistance Decade

Operation manual

MEATEST



Content

1. USE OF THE INSTRUMENT	4
2. CONTENTS OF DELIVERY	4
3. TECHNICAL DATA	4
4. PREPARATION FOR USE	7
4.1. SWITCHING ON	7
4.2. WARM-UP TIME.....	7
5. DESCRIPTION	7
5.1. FRONT PANEL.....	7
5.2. REAR PANEL.....	9
6. OPERATION	9
6.1. SWITCH ON AND OFF	9
6.2. STANDARD MODE.....	10
6.3. SETUP MODE	10
6.4. CALIBRATION MODE.....	13
7. PERFORMANCE VERIFICATION TEST	16
8. REMOTE CONTROL	18
8.1. COMMANDS	18
8.2. COMMAND LIST.....	18
8.3. REMOTE CONTROL RS232.....	21
8.4. REMOTE CONTROL IEEE488 (OPTIONALY)	21
8.5. DEMO PROGRAM	22
9. MODULE 19" (EXTRA ORDERED OPTION)	22
10. ELECTRIC FUNCTION	22
11. MECHANICAL CONSTRUCTION	22
11.1. BATTERY MAINTENANCE	22
11.2. BATTERY REPLACEMENT.....	23
12. ORDERING INFORMATION – OPTIONS	23
CERTIFICATE OF CONFORMITY	24

1. Use of the instrument

Resistance decade M-622 is precise programmable resistance decade in range 1.000 00 Ohm to 1 200 000 Ohm. It is designed for checking of parameters of resistance meters and regulators and process meters, which use external resistance sensors for non-electric quantity measuring. Set resistance value is created via appropriate combination of physical resistors. Decade is equipped with build-in function of direct simulation of most frequent temperature Pt and Ni sensors. Low thermal voltage relays and stable foil resistors with low temperature coefficient are used as main parts of the decade. Actual set values are displayed on the front panel display. Resistance decade is supplied from internal battery. External power line adapter is delivered as power line source and as internal battery charger in one. M-622 is sophisticated instrument with its own re-calibration procedure. The procedure enables to correct any deviation in resistance without any mechanical adjusting.

Instrument is especially suitable for automatic testing procedures. RS232 line (optionally IEEE488 bus) is used for connecting decade to the computer.

2. Contents of delivery

RS232 version

Resistance decade M622-V1xxx
Power line adapter
Cable RS-232
Demo program
User's manual
Test report

IEEE488 version

Resistance decade M622-V2xxx
Power line adapter
Demo program
User's manual
Test report

3. Technical data

Only values, functions, ranges with signed accuracy in relative or absolute expression or where limits are specified, are guaranteed.

Resistance range	:	1.000 00 Ω - 1 200 000 Ω SHORT, OPEN terminals (version M622-Vx1xx only)
Pt sensor temperature simulation	:	-200.000 $^{\circ}\text{C}$... 850.000 $^{\circ}\text{C}$ (-328 $^{\circ}\text{F}$... 1562 $^{\circ}\text{F}$)
Ni sensor temperature simulation	:	-60.000 $^{\circ}\text{C}$... 300.000 $^{\circ}\text{C}$ (-76 $^{\circ}\text{F}$... 572 $^{\circ}\text{F}$)
Type of temperature sensors	:	Pt10 ... Pt20000, Ni10 ... Ni20000
Resolution	:	0.000 01 Ω for 1.000 00 ... 10.000 00 Ω 0.000 1 Ω for 10.0001 ... 100.000 0 Ω 0.001 Ω for 100.001 ... 400.000 Ω 0.01 Ω for 400.01 ... 1 200.00 Ω 0.1 Ω for 1200.1 ... 30 000.0 Ω 1 Ω for 30000 ... 1 200 000 Ω 0.001 $^{\circ}\text{C}$ for Pt10 ... Pt300, Ni10 ... Ni300 0.01 $^{\circ}\text{C}$ for Pt301 ... Pt10000, Ni301 ... Ni10000

Pt temperature standards	:	IEC 751 (1,3850 for IPTS68) IEC 751 (1,3851 for ITS90) US (US/JIS) (1,3916)
Ni temperature standards	:	DIN 43760 (6180)
Resistance temperature coefficient	:	< 1 ppm/ °C (1 Ω - 2000 Ω) on terminals R4W < 1 ppm/ °C (100 Ω - 1200 kΩ) on terminals R2W < 5 ppm/ °C (2 kΩ - 10 kΩ) on terminals R4W
Maximal dissipation power	:	0,3 W
Maximal voltage	:	50 V DC, 50 Vef AC on terminals R4W 120 V DC, 50 Vef AC on terminals R2W
Connection of output terminals	:	2, 4 wire
Connection of temperature sensors	:	2, 3 or 4 wire
Reaction time *	:	6 ms
Terminals	:	instrument terminals diameter 4mm, gold plated
Interface	:	RS232 as standard (IEEE488 optionally)
Power supply	:	internal battery 12 V type LONG B-WP 1.9-12 power line adapter 15VDC/2A 100 – 240 V
Operating period from battery	:	6 hours
Reference temperature	:	+18 °C ... +28 °C
Working temperature	:	+5 °C ... +40 °C
Storing temperature	:	-10 °C ... +50 °C
Housing	:	ALU
Dimensions (table version)	:	W 364 mm, H 111 mm, D 316 mm (without holder)
Dimensions (19" module)	:	W 483 mm, H 133 mm, D 316 mm
Weight	:	4.5 kg

Isolation resistance between output terminals and housing : > 2 GΩ (at 500V DC)

* Reaction time means time interval between setting up value from front panel or receiving command from remote control bus and settling set-up value on output terminals.

Notes:

- Only data shown with tolerance or with band of limits are tested. All other values have informative character.
- During over-switching, resistance circuit may be opened for a period about 1 ms.

Accuracy

Specified accuracy is valid after 10 minutes warm up in temperature range 23 ± 5 °C. Uncertainties include long-term stability, temperature coefficient, linearity, load and line regulation and traceability of factory to National calibration standards. Accuracies assigned in % are related to the set value. Specified accuracy is one-year accuracy.

Resistance accuracy (terminals R4W)

Range	Accuracy
1.00000 Ω - 400.000 Ω	0.003 % + 3 m Ω
400.01 Ω - 2000.0 Ω	0.005 %
2000.1 Ω - 10000.0 Ω	0.015 %

Maximal thermoelectric voltage on terminals R4W is 1 μ V.

Resistance accuracy (terminals R2W)

Range	Accuracy
1.00000 Ω - 2000.0 Ω	0.005 % + 10 m Ω
2000.1 k Ω - 200.000 k Ω	0.005 %
200.001 k Ω - 1200.000 k Ω	0.01 %

Maximal thermoelectric voltage on terminals R2W in resistance range 1 Ω to 2 k Ω is 5 μ V and in range 2 k Ω to 1.2 M Ω is 15 μ V.

Pt temperature sensor simulation accuracy

Temperature range	Pt100 (terminals R4W)	Pt200 (terminals R4W)	Pt500 (terminals R4W)	Pt1000 (terminals R4W)	Pt10000 (terminals R2W)
-200.000 ... 200.000 °C	0.02 °C	0.02 °C	0.02 °C	0.04 °C	0.04 °C
200.001 ... 500.000 °C	0.03 °C	0.04 °C	0.06 °C	0.1 °C	0.06 °C
500.001 ... 850.000 °C	0.04 °C	0.06 °C	0.15 °C	0.2 °C	0.1 °C

Ni temperature sensor simulation accuracy

Temperature range	Ni100 (terminals R4W)	Ni1000 (terminals R4W)	Ni10000 (terminals R2W)
-60.000 ... 300.000 °C	0.02 °C	0.04 °C	0.04 °C

Temperature coefficient outside of the reference temperature range is 10 % of the stated specification per °C.

Short and Open simulation (version M622-Vx1xx only)

When function Short is selected, output resistance is lower than 100 m Ω (typically 50 m Ω). Maximal allowed current is 500 mA.

When function Open is selected, output resistance is higher than 1 G Ω . Maximal allowed voltages are 50 V ef on terminals R4W and 120 V DC, 50 Vef AC on terminals R2W.

Note:

Resistance values in range 1 Ω - 1.2 M Ω are calibrated absolutely. Resistance value is not defined against SHORT position. Functions Short and Open positions are intended only for functional checking of tested instrument.

4. Preparation for use

M-622 Resistance decade is supplied from internal battery or from external power line adapter. Range of power line voltage is from 100 V to 240 V 50/60 Hz. M-622 is laboratory device. Its accuracy is guaranteed in temperature range 23 ± 5 °C. Instrument is aimed for use in horizontal or slope position. The angle of slope is determined by downcast holder.

After unpacking put the instrument on flat desk. If the instrument was stored out of range of reference temperatures, let it stabilize for one hour.

4.1. Switching on

If the instrument is supplied from internal battery only, push the button POWER. If power line adapter is connected, decade will switch on automatically. After switching on internal tests are performed for approx. 3s. On the display type name of the instrument and manufacturer are displayed during internal test. After finishing, setting to the position before last switching off is performed. Factory setting is resistance mode, value 100Ω .

4.2. Warm-up time

Decade can operate immediately after switching on. After 10 min. warm-up period it meets specified accuracy. During warm-up period it is not recommended to perform recalibration.

5. Description

5.1. Front panel

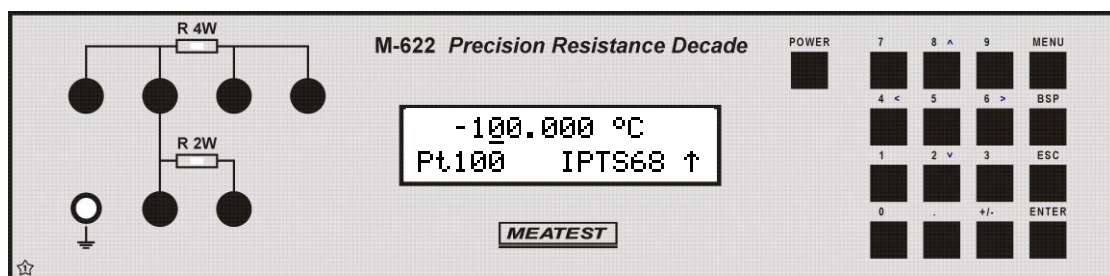

On the front panel there are located all main control keys, display and output terminals.



Keyboard

Numerical values can be entered from the numerical part of keyboard. Keys with number 2, 4, 6, 8 have also next meaning as display cursor keys. Except numerical there are following keys in the keyboard:

<i>Key</i>	<i>Meaning</i>
MENU	enters to the SETUP/CALIBRATION MENU.
BSP	deletes last entered number.
ESC	cancels last entered value or leaves last set mode
ENTER	confirms set value or confirms selected item in MENU or switches between numerical function (black label) and display cursor function (blue label) of the keys 2, 4, 6, 8. Switching over is indicated with symbol (↑) in right low corner of the display.
POWER	switches on and off the decade. When switching off is requested, two-times the key must be pushed to confirm switching off.

Display

Two-row alphanumeric display is used for displaying all information. Main value, i.e. simulated temperature or output resistance is displayed in upper row. Auxiliary information is displayed in lower row. Depending on status following symbols can be displayed in right low corner:

- ↑ keys 2, 4, 6 and 8 are switched to the cursor function (blue labels are valid)
-  decade is in remote control via RS232 (IEEE488 optionally)
-  internal battery is out of power
-  power line adapter is connected

Output terminals

Output resistance is available on either R4W or on R2W output terminals. Upper four terminals R4W enable 2 and 4 wire connection of resistance decade and 2, 3 and 4 wire connection, if decade is used as Pt/Ni temperature sensor simulator. Resistance range on these terminals is from 1 Ω to maximal R = 10 kΩ. Upper limit R depends on setting of parameter 4W < 2W. Lower line of terminals with label R2W can be used for two-wire connection only. Total resistance range on these terminals is from R = 1 Ω to 1.2 MΩ. Value of lower limit R depends on setting of parameter 4W < 2W.

Decade automatically switches between R2W and R4W output terminals according to resistance value. Low resistance values are connected always to R4W terminals. Resistance value, where over-switching from R4W terminals to R2W terminals is performed can be set in MENU, parameter 4W < 2W. Range of this point setting covers values from 0 Ω to 10 kΩ and can be set with 1Ω resolution. Resistance of preset 4W < 2W value is always available still on R4W terminals. When 4W < 2W value is set to 0 Ω, R2W terminals are used as output only. Recommended 4W < 2W value is 2000 Ω.

Active terminals are indicated with lighting LED diode on front panel.

Left terminal with symbol “GROUND” is connected with the housing.

5.2. Rear panel

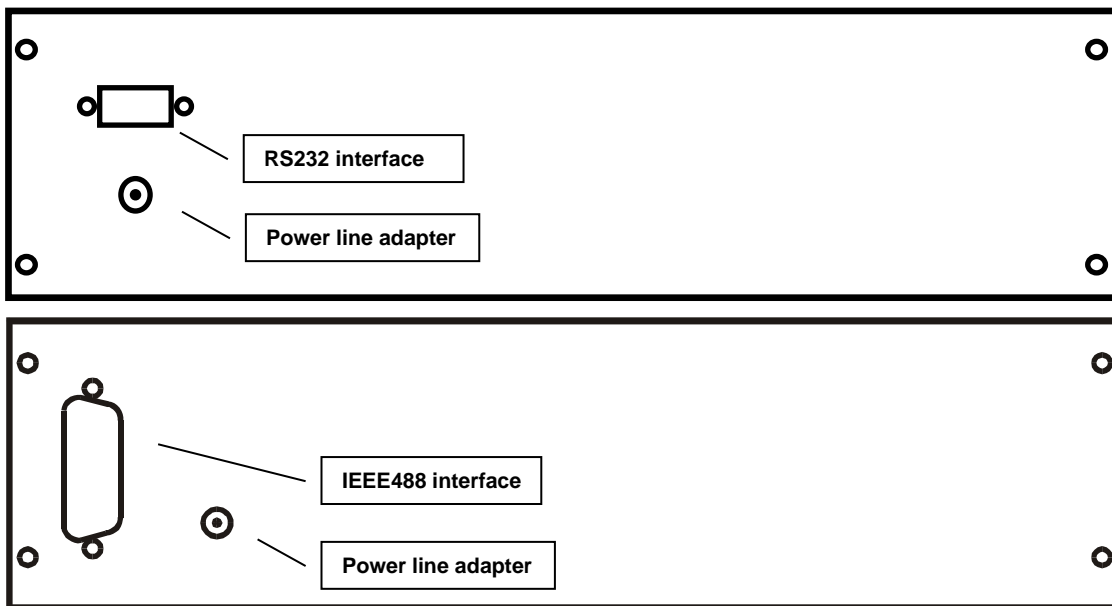

On the rear panel there are located power supply connector, interface RS-232 connector (optionally IEEE488 connector) and serial number plate.

6. Operation

6.1. Switch on and off

When supplied from power line adapter, decade is automatically switched on all this time the adapter is connected to the power source.

When supplied from internal battery (power line adapter is not connected to the power line connector, or adapter is not connected to the power source), decade must be switched on by pushing the key POWER. To switch off the decade, push the same key two times. When supplied from internal battery, decade is automatically switch off, if for last 20 minutes no one key was pushed or if internal battery is discharged. One minute before automatic switching off, decade displays symbol and beeps  to warn the user.

6.2. Standard mode

After switching on decade comes to standard mode. Following information is shown on the display:

```

-100.000 °C
Pt100    IPTS68 ↑

```

In the upper row actually simulated temperature [°C] or generated resistance [Ω] is displayed. In the lower row type of simulated temperature sensor (Pt100), set-up temperature scale IPTS68, ITS90 according to the IEC751 standard or US according to the US/JIS standards are displayed. Arrow symbol in right corner informs, that cursor function of keys 2, 4, 6, 8 is initialized (blue signs on front panel foil). Buttons ↑ ↓ enable step up or down number on active position. With buttons ← → active position of cursor can be moved left or right. With button ENTER can be switched between cursor and numerical keyboard in this mode. After pushing the key MENU, SETUP function is activated.

Use of cursor keys

Cursor keys ↑ ↓ enables to increase or decrease the number on active position. Active position is signed by symbol _ under the number place. With cursor keys ← → active position of the cursor can be changed.

Pushing the key ENTER switches keys 2, 4, 6, 8 function between cursor and numerical.

Numerical keyboard

With numerical keys value of temperature (or resistance) can be directly entered. Recently entered value is displayed in brackets under the actually set value. To confirm new value push the key ENTER.

```

-100.000 °C
[ 162.8 ]

```

Pushing the key ENTER switches keys 2, 4, 6, 8 function between cursor and numerical. Press ESC key to exit setting value from numerical keyboard mode. BSP key deletes last entered number.

6.3. Setup mode

This mode enables to set or display some auxiliary parameters. To enter this mode push the key

```

Function Pt100
Pt100    ↑

```

MENU in standard mode. To leave setup mode push the key ESC. With cursor keys \uparrow \downarrow following items in setup menu can be displayed:

Function

With buttons \leftarrow \rightarrow following functions can be set-up:

- R - resistance function. Total range of resistance is 1.00000 Ω to 1200000 Ω .
- Pt (68) - simulation of Pt temperature sensors according to standard IEC 751 (temperature scale IPTS68, coefficient 1,3850). Range of setting -200 $^{\circ}\text{C}$ to 850 $^{\circ}\text{C}$ (-328 $^{\circ}\text{F}$ to 1562 $^{\circ}\text{F}$). Parameter R0 (resistance at 0 $^{\circ}\text{C}$) can be set-up in range 10 Ω to 20 000 Ω .
- Pt (90) - simulation of Pt temperature sensors according to standard IEC 751 (temperature scale ITS90, coefficient 1,3851). Range of setting -200 $^{\circ}\text{C}$ to 850 $^{\circ}\text{C}$ (-328 $^{\circ}\text{F}$ to 1562 $^{\circ}\text{F}$). Parameter R0 (resistance at 0 $^{\circ}\text{C}$) can be set-up in range 10 Ω to 20 000 Ω .
- Pt (US) - simulation of Pt temperature sensors according to standard US/JIS (temperature scale ITS90, coefficient 1,3851). Range of setting -200 $^{\circ}\text{C}$ to 850 $^{\circ}\text{C}$ (-328 $^{\circ}\text{F}$ to 1562 $^{\circ}\text{F}$). Parameter R0 (resistance at 0 $^{\circ}\text{C}$) can be set-up in range 10 Ω to 20 000 Ω .
- Ni - simulation of Ni temperature sensors according to standard DIN 43760 (coefficient 6180). Range of setting -60 $^{\circ}\text{C}$ to 300 $^{\circ}\text{C}$ (-76 $^{\circ}\text{F}$ až 572 $^{\circ}\text{F}$). Parameter R0 (resistance at 0 $^{\circ}\text{C}$) can be set-up in range 10 Ω to 20 000 Ω .
- User - by user defined temperature function. As default, NTC thermistor sensor with temperature function

$$R(T) = 330 * \exp(-4050 * ((1/298,15) - (1/(T+273,15))))$$
is delivered. Range of simulation is -30 $^{\circ}\text{C}$ to 110 $^{\circ}\text{C}$.
This function can be changed in MEATEST Company only (extra ordered option). Please specify in your order.
- Short - simulates short on the output terminals. Function Short is extra ordered option.
- Open - simulates open on the output terminals. Function Open is extra ordered option.

Items from MENU are displayed on lower row. After selecting an item and pressing the button ENTER, symbol of this new selected temperature/resistance function is written to upper row. Selected function is valid even if the instrument is switched off and on again (except of Short and Open functions).

R0 (Pt,Ni) (resistance at 0 $^{\circ}\text{C}$)

The function enables to set-up parameter R0 for temperature sensors. Set value R0 is valid for both Pt and Ni sensors. New value can be written after changing keyboard meaning to numerical by pushing ENTER. Allowed range is from 10 to 20 000 Ω . To confirm new value press ENTER. New value is valid even if the instrument is switched off and on again.

4W < 2W (the highest resistance value on R4W terminals)

The function enables to pre-set resistance value, where instrument automatically switches active output terminals from R4W to R2W and back. Resistance values higher than 10 000 Ω are available only on terminals R2W. Lower values than 10 000 Ω can be available either on R2W terminals – but with a little bit worse accuracy or on R4W terminals with the lowest uncertainty. Resistance point, where decade swiches between both terminals can be modiflicated here. New value can be written after changing keyboard meaning to numerical by pushing ENTER. Allowed range is from 10 to 10 000 Ω . To confirm new value press ENTER. New value is valid even if the instrument is switched off and on again.

T. unit (temperature unit)

With buttons ← → either °C or °F can be set-up here. Possibilities are shown in lower row. After selecting one of them and pressing the button ENTER appropriate symbol is written to upper row. New value is valid even if the instrument is switched off and on again.

Baud rate RS-232 (optionally IEEE488 address)

In standard version, the function involves to set parameter baud rate of RS-232 interface. With keys ← → any value from the row 300, 600, 1200, 2400, 4800, 9600 or 19200 Bd can be set. Set baud rate is displayed in lower row. To change currently valid value to the new value press the key ENTER. The newly set baud rate is written into the upper row.

If the decade is optionally equipped with IEEE488, instead of “Baud rate” you can set IEEE488 address of instruments.

In decade with IEEE488 interface, IEEE488 address can be set-up here. The address range is 0 to 30. The last set baud rate is valid even if the instrument is switched off.

Lighting

Enables or disables lighting of the display. With keys ← → values OFF (lighting is switched off), 30 s (lighting is switched on for 30 s after last key pressing), 5m (lighting is switched on for 5 minutes after last key pressing) or ON (lighting is switched on) can be set. Selected parameter is displayed in lower row. To change currently selected parameter press the key ENTER. The newly set parameter is written into the upper row.

If the instrument is supplied from the external power adapter, lighting is switched on permanently.

Note: Display lighting influences significantly operating period from the internal battery. If not used when instrument is supplied from internal battery, the working period can be lengthen about 50%.

Calibration mode password setting

Calibration password is a five-digit number, which must be entered to access the calibration mode. If the password is set to “00000”, this information is displayed in the Setup menu, otherwise only symbols “*****” are shown.

Password can be changed. New password can be entered directly from keyboard after changing keyboard meaning to numerical by pushing ENTER. If previous password was “00000”, simply type new 5-digit code and press ENTER. New password is saved and cannot be read in MENU. If previous password was non-zero, new password can be entered in two steps. In the first step original password must be entered and confirmed by pressing ENTER. If it is correct symbols “00000” are displayed. Now new password can be entered and saved according to above described procedure.

New password is valid even if the instrument is switched off and on again.

Note: it is advisable to write down actual password if changed. If you forget the calibration code, you have to send the decade to the manufacturer.

Serial number

Displays the serial number of the decade. The parameter cannot be changed.

6.4. Calibration mode

In this mode resistance elements of the decade can be recalibrated. Access to the calibration mode is enabled after double pushing the key MENU from the standard mode or after single pushing the same key from the SETUP mode.

Correct password must be entered before calibration. Without correct password the access to the calibration mode is refused. Default factory set calibration code is "00000". Return to standard mode is possible after pushing the key ESC.



```
Enter password :  
00000
```

Recalibration procedure consists of measuring of 36 basic resistance values and entering their actually measured data. Among calibration values can be moved with keys \uparrow \downarrow .

In following table nominal values of calibration points and requested recalibration accuracy are described:

Standard (terminals)	Nominal value	Requested Accuracy
R00 (R4W)	2,0 Ω	1 m Ω
R01 (R4W)	3,9 Ω	1 m Ω
R02 (R4W)	7,8 Ω	1 m Ω
R03 (R4W)	15,4 Ω	1 m Ω
R04 (R4W)	30,5 Ω	1 m Ω
R05 (R4W)	60,5 Ω	1 m Ω
R06 (R4W)	120 Ω	2 m Ω
R07 (R4W)	237 Ω	3 m Ω
R08 (R4W)	464 Ω	6 m Ω
R09 (R4W)	909 Ω	15 m Ω
R10 (R4W)	1780 Ω	30 m Ω
R11 (R4W)	3480 Ω	100 m Ω
R12 (R4W)	6870 Ω	250 m Ω
R13 (R4W)	13,5 k Ω	500 m Ω
R14 (R4W)	26,6 k Ω	1 Ω
R15 (R4W)	52,2 k Ω	5 Ω
R16 (R4W)	103 k Ω	10 Ω
R17 (R4W)	202 k Ω	20 Ω
R18 (R4W)	398 k Ω	40 Ω
R19 (R4W)	780 k Ω	80 Ω
R20 (R4W)	1540 k Ω	200 Ω
R21 (R4W)	3020 k Ω	400 Ω
R22 (R4W)	5920 k Ω	1 k Ω
R23 (R4W)	12 M Ω	5 k Ω
R24 (R4W)	23 M Ω	50 k Ω
R25 (R4W)	48 M Ω	200 k Ω
R26 (R4W)	100 M Ω	500 k Ω
R27 (R2W4W)	1780 Ω	40 m Ω
R28 (R2W4W)	3830 Ω	80 m Ω
R29 (R2W4W)	7870 Ω	100 m Ω
R30 (R2W4W)	15,8 k Ω	200 m Ω
R31 (R2W4W)	34 k Ω	500 m Ω
R32 (R2W4W)	75 k Ω	1 Ω
R33 (R2W4W)	150 k Ω	4 Ω
R34 (R2W4W)	301 k Ω	10 Ω
R35 (R2W4W)	602 k Ω	20 Ω

Process of calibration consists of measuring partial resistances and writing their actual values into the decade:

- Set the first calibration point (resistance element). Use keys $\uparrow \downarrow$ to set the element.

- Measure resistance of the selected element. Use ohm-meter with appropriate accuracy in 4-wire connection and with appropriate accuracy.
- Change function of the keyboard to the numerical one by pushing the key ENTER.
- Write measured resistance value (there is original value in the first row and newly entered value in the second row). Newly entered value must to be written down in units Ohm.

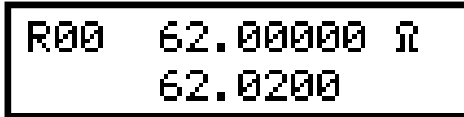

- Confirm new calibration data by pushing the key ENTER.
- Repeat above described procedure for all resistance elements.

Recommended connection of standard ohm-meter for calibration points R00 to R26 (terminals R4W) :

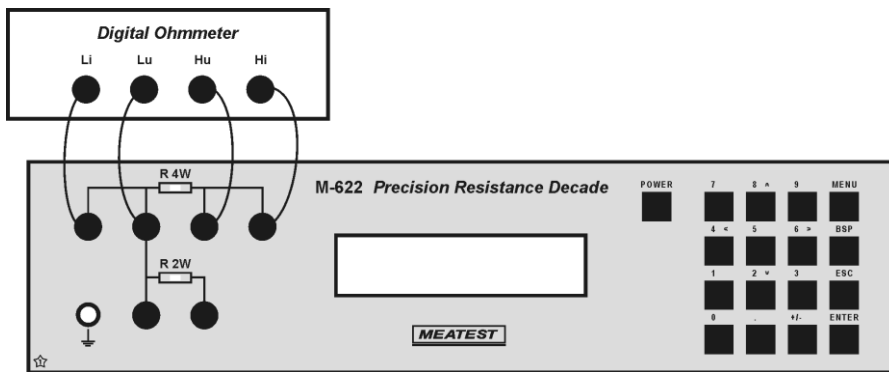

Recommended connection of standard ohm-meter for calibration points R27 to R35 (terminals R2W) :

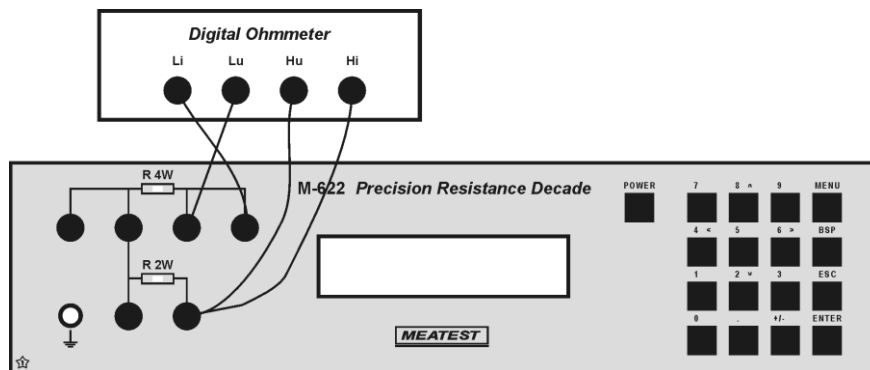

7. Performance verification test

Parameter verification procedure is described in the chapter. Verification procedure is based on measuring resistance on the decade output terminals with standard multimeter in recommended points.

Required equipment

- Ohm-meter nominal accuracy 0.001% in range 1 Ω to 1.2 M Ω (type Wavetek 1281 or similar)

Decade setting

Switch decade to the resistance function. Connect standard multimeter to the decade output terminals. Use four-wire connection technique.

Range of the test

- output resistance on terminals R4W checking
- output resistance on terminals R2W checking

Procedure

Use following procedure to perform parameter verification test.

1. Switch both instruments on and let them for 1 hour stabilise in the laboratory with ambient temperature 23 ± 2 °C. Connect resistance decade terminals R4W to the standard ohm-meter (multimeter). Set value 4W<2W to 10 k Ω in SETUP menu.
2. Check resistance value in points according to Table I.

I. Maximal deviations on terminals R4W

Nominal value [Ω]	Max. deviation [m Ω]
1.00000	3.03
2.00000	3.06
5.00000	3.15
10.00000	3.3
20.0000	3.6
50.000	4.5
100.000	6.0
200.00	9.0
500.00	25
1000.0	50
2000.0	100
5000.0	750
10000.0	1500

3. Connect standard ohm-meter to R2W terminals on resistance decade. Use four-wire connection to 10 k Ω . Above this point both two-wire and four-wire connection can be used. Set function 4W<2W to 0 Ω in SETUP menu.
4. Check resistance value in points according to Table II.

II. Maximal deviations on R2W terminals

Nominal value [Ω]	Max. deviation [Ω]
1.00000	0.01
10.00000	0.011
100.000	0.015
1000.0	0.060
2000.0	0.1
5000.0	0.25
10000.0	0.5
20000.0	1.0
50000	2.5
100000	5.0
200000	20
500000	50
1000000	100
1200000	120

8. Remote control

Standard version is equipped with RS232 bus. IEEE488 version is described in chapter 8.4. Commands for both versions are the same.

8.1. Commands

Communication between decade and computer consists of flow of periodically alternating commands type command-response or query-response. Command is always a letter followed by parameter and ended by control sign <cr> or <lf>. Response is always ended with control signs <cr> <lf>.

Syntax description

- <DNPD> = Decimal Numeric Program Data, this format is used to express decimal number with or without the exponent.
- <CPD> = Character Program Data. Usually, it represents a group of alternative character parameters. E.g. {0 | 1 | 2 | 3}.
- ? = A flag indicating a request for the value of the parameter specified by the command. No other parameter than the question mark can be used.
- (?) = A flag indicating a request for the parameter specified by the command. This command permits a value to be set as well as requested.
- <cr> = carriage return. ASCII code 13. This code executes the program line.
- <lf> = line feed. ASCII code 10. This code executes the program line.

8.2. Command list

Value setting / reading

A (?) <DNPD>

The command sets resistance value (resistance function) or temperature value (temperature sensor simulating function).

<DNPD>

It represents resistance value in Ohm or simulated temperature in oC. When temperature parameter is used, both negative and positive values are acceptable. For resistance parameter positive value only is acceptable. Limit values are shown in chapter "Technical data".

In case of control, the decade confirms correct setting with string „Ok <cr><lf>”.

In case of query, M-622 returns set resistance/temperature value in the same format as it is on the display (number of decimal places). For example value -120 °C is returned as -120.000<cr><lf>. Positive numbers are sent without polarity sign.

Example :

Command „A123.564 <cr>” sets temperature 123.564 °C if decade is in temperature simulation function and 123.564 Ω if decade is in resistance function.

If query „A?<cr>” is sent, decade returns response in format „123.564<cr><lf>”.

Decade function setting

F <CPD> { 0 | 1 | 2 | 3 | 4 | 5 | S | O }

Following function can be set:

- 0 resistance mode
- 1 Pt (68) temperature sensor simulation
- 2 Pt (90) temperature sensor simulation
- 3 Pt (US) temperature sensor simulation
- 4 Ni temperature sensor simulation
- 5 User temperature sensor simulation
- S Short simulation (extra ordered option)
- O Open simulation (extra ordered option)

M-622 confirms execution with string „Ok <cr><lf>”.

Example :

„F1<cr>” sets Pt100 sensor simulation.

I/D (device identification)

***IDN?**

Response contains name of manufacturer, model type number, serial number, firmware version

Example :

If query „*IDN?<cr>” is sent, decade returns response:
„MEATEST,M622,462351,2.4 <cr><lf>”.

Switching off

P0

The command will switch the decade off. The command is executed if decade is supplied from internal battery only. Correct execution is confirmed with string „Ok <cr><lf>”.

Example :

„P0<cr>” switches decade off (if not used external power adapter).

R0 setting / reading

R (?) <DNPD>

Command sets resistance value R0 at temperature 0oC. Set value R0 is valid for all types of simulated temperature sensors.

<DNPD>

It represents resistance value R0 in Ω . Limits are shown in chapter Technical data. M-622 confirms execution with string „Ok <cr><lf>”. In case of query M-622 returns set value in Ω .

Example :

„R100 <cr>” sets value R0 to 100 Ω (Pt100, Ni100).

After query „R?<cr>” decade returns string „100<cr><lf>”.

Temperature unit setting**U <CPD> { 0 | 1 }**

Command sets used temperature unit.

- 0 sets degree Celsius °C
- 1 sets degree Fahrenheit °F

M-622 confirms execution with string „Ok <cr><lf>”.

Example :

„U0<cr>” sets °C as temperature unit.

Status reading**V?**

M-622 returns device status in form „FxUx <cr><lf>“. On positions of signs „x“ there are values corresponding to the actual status of decade.

Example :

After query „V?<cr>” decade returns for example string „F2U0<cr><lf>”, which means Pt (90), °C actual setting.

Setting/reading of value for switching over terminals 2W/4W**W (?) <DNPD>**

This command sets value, where output resistance is switched from R4W to R2W and back.

<DNPD>

It represents resistance value in Ω . Limits are shown in chapter Technical data. M-622 confirms execution with string „Ok <cr><lf>”. In case of query M-622 returns set value in Ω .

Example :

„W2000 <cr>” sets value to 2000 Ω .

After query „W?<cr>” decade returns string „2000<cr><lf>”.

When unknown command is received M-622 returns string "? <cr><lf>“. Correctly executed command is confirmed with string "Ok <cr><lf>. When correct query is received M-622 returns response in above described format. All commands must contain sign <cr> or <lf> at the end. Both small and large letters can be used.

8.3. Remote control RS232

Transmission baud rate can be selected from 300 to 19200 Bd. Number of data bits is 8, number of stop bits is 1, parity is not used. For data flow control neither hardware handshake (RTS/CTS) nor program handshake (XON/XOFF) is used. RS 232 line is from other electronic circuits galvanically isolated

RS-232 connection

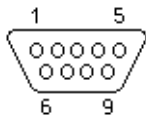

Pin	Label	I/O	Description
2	TXD	output	Transmitter
3	RXD	input	Receiver
5	GND	-	Ground

9 pin connector D-SUB MALE

Cable between decade and computer description (configuration 1:1)

Computer	D-Sub 1	D-Sub 2	M-622
Receiver	2	2	Transmitter
Transmitter	3	3	Receiver
Ground	5	5	Ground

8.4. Remote control IEEE488 (optionaly)

The list of commands is valid for version of decade with IEEE488 interface.

The instrument performs the following functions based on IEEE488 bus commands:

SH1, AH1, T5, L3, RL1, DC1

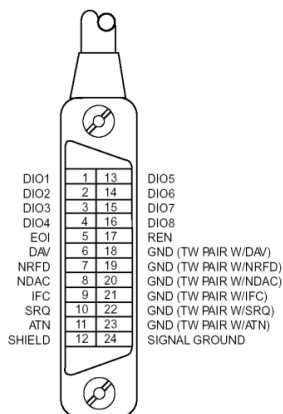

The instrument also recognizes the following general commands:
 DCL Device Clear - resets the instrument to its basic state
 SDC Selected Device Clear - resets the instrument to its basic state
 GTL Go To Local - switches the remote control off
 LLO Local Lock Out - switches the local control off, the instrument cannot be controlled from the front panel

Commands are identical to the commands for RS-232 interface. Detailed description is shown in chapter 8.2.

8.5. Demo program

A simple operating program DecadeAssistant is supplied with the decade in order to provide easy operation of the instrument from the computer, and to check the RS-232 line (IEEE488 bus) of the instrument. The installation CD ROM contains a program (for MS WINDOWS only), you can communicate with the instrument through standard serial line (IEEE488) with. For example, you can set value or function on the decade. For IEEE488 connection this DecadeAssistant requires properly configured National Instruments IEEE488 card.

Download on www.meatest.com.

9. Module 19" (extra ordered option)

RTD simulator can be ordered as 19" module for easy assembling into a 19" rack. Module height is 3HE.

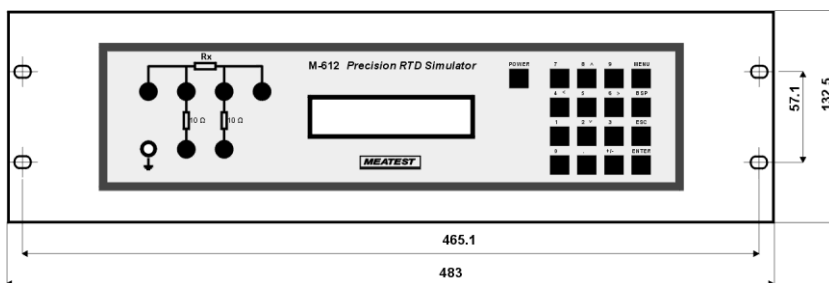

10. Electric function

Resistance elements are switched to the output terminals through reed relays in binary code system. The relays used are types with low thermoelectric voltage. The resistors are of foil or metal type with low temperature coefficient. Metal housing is connected to the ground terminal only. The board with resistors and relays creates independent mechanical block.

CPU unit with one-chip micro-controller generates all necessary internal control signals. Calibration data and set-up parameters are saved in EEPROM memory.

11. Mechanical construction

Decade housing is standardised aluminium type one. Keyboard with display and output terminals are located on the front panel. External power supply connector and RS-232 connector are located on the rear panel. Internal battery is fixed to the rear panel inside the housing.

11.1. Battery maintenance

Period for fully battery charging is approx. 40 hours. If the instrument has been stored for more than 3 months without connected external power line adapter, battery should be charged.

11.2. Battery replacement

Internal battery is sealed lead-acid maintenance-free long-life rechargeable battery with voltage 12V and capacity 2.6Ah.

To replace battery use following procedure:

- Disconnect external power supply adapter and RS-232 (IEEE488) cable.
- Switch decade off.
- Dismount 4 screws located in the corners of the rear panel.
- Remove slightly top cover.
- Disconnect connectors from the battery and dismount metal belt to release battery.
- Replace battery pack.
- Connect fresh battery and mount it into the case in opposite procedure.

12. Ordering information – options

Bus

M622-V1xxx - RS232

M622-V2xxx - IEEE488

Additional functions

M622-Vx0xx - none

M622-Vx1xx - Short/Open function

Housing

M622-Vxx0x - table version

M622-Vxx1x - module 19“, 3HE

Manufacturer

MEATEST, s.r.o.
Zelezna 509/3, 619 00 Brno
Czech Republic
www.meatest.com

tel: +420 – 543 250 886
fax: +420 – 543 250 890
meatest@meatest.cz



Certificate of conformity

According to EN ISO/IEC 17050-1:2010 standard as well as 2014/30/EU and 2014/35/EU directives of European Parliament and European Council, MEATEST, spol. s r. o., manufacturer of M-622 Precision Resistance Decade based in Železná 3, 619 00 Brno, Czech Republic, declares that its product conforms to following specifications:

Safety requirements

- EN 61010-1:08 ed. 2:2011

Electromagnetic compatibility

- EN 61000 part 3-2 ed. 3:2006 + A1:2010 + A2:2010
- EN 61000 part 3-3 ed. 2:2009
- EN 61000 part 4-2 ed. 2:2009
- EN 61000 part 4-3 ed. 3:2006 + A1:2008 + A2:2011
- EN 61000 part 4-4 ed. 3:2013
- EN 61000 part 4-5 ed. 2:2007
- EN 61000 part 4-6 ed. 3:2009
- EN 61000 part 4-11 ed. 2:2005
- EN 61326-1 ed. 2:2013

Brno

April 16th, 2014

Place

Date

Signature